

REV.NO.	REVISION DESCRIPTION	DRAWN / DATE	REVIEWED / DATE	APPROVED / DATE
△	ISSUE FOR APPROVAL	HSS/050531	KCH/050531	LYH/050531
△	ADDED A DETAIL	HSS/051108	KCH/051108	LYH/051108
△	DRAWING ARRANGEMENT	OSS/120320	JCS/120320	LYH/120320

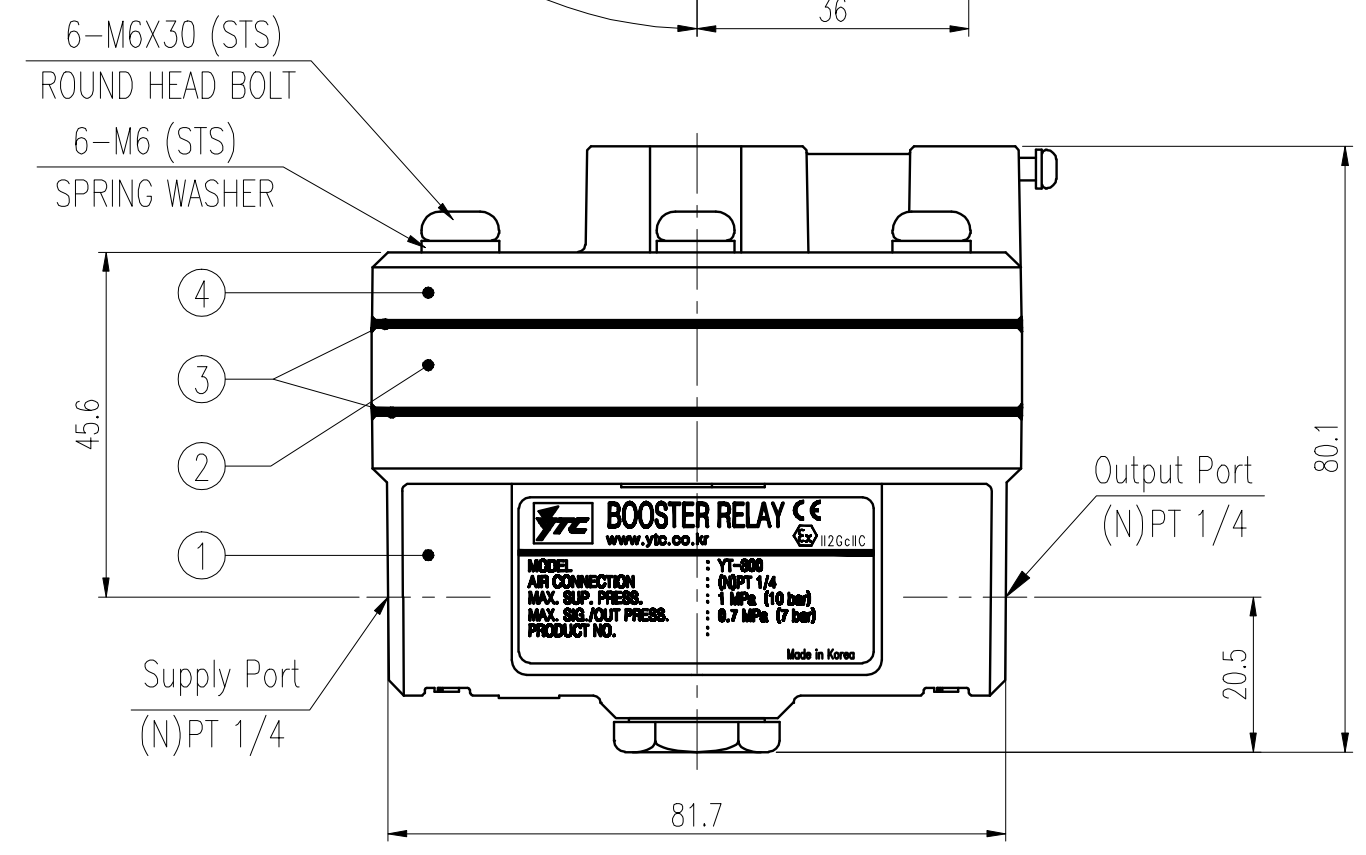
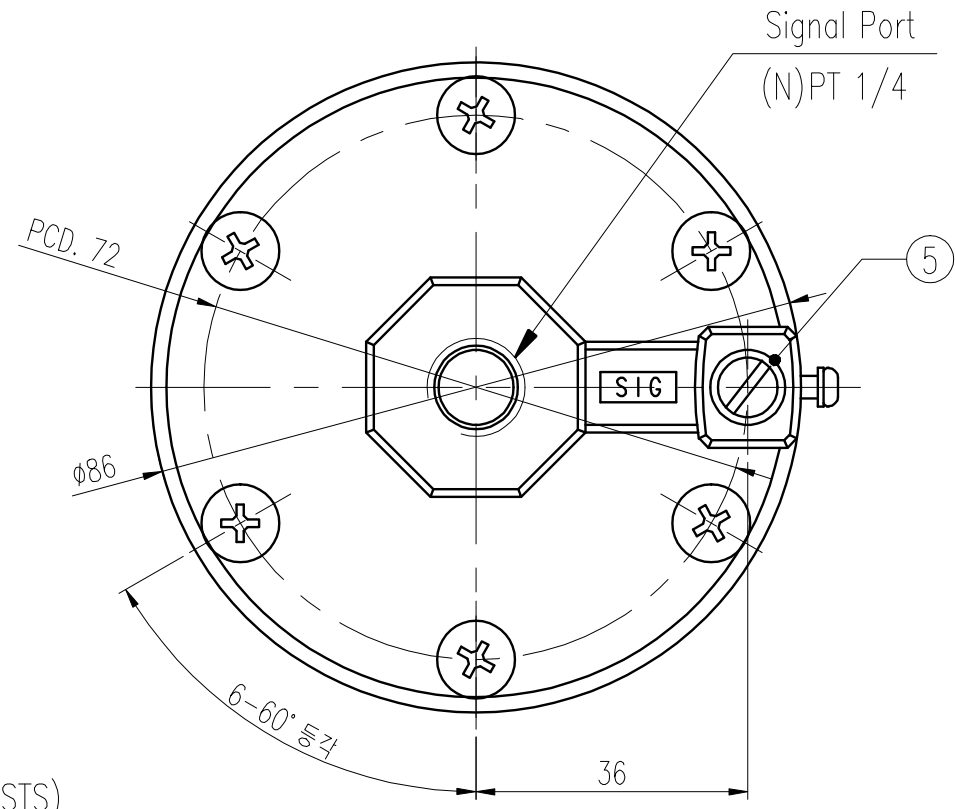

6-M6X30 (STS)
ROUND HEAD BOLT
6-M6 (STS)
SPRING WASHER

SPECIFICATIONS

Max. Supply Pressure	1MPa (10bar)
Max. In/Out Pressure	0.7MPa (7bar)
In/Out Pressure Ratio	1 : 1
Flow Capacity(Cv)	1.02
In/Out Connection	PT(NPT) 1/4
Signal Connection	PT(NPT) 1/4
Ambient Temperature	-20 ~ 70°C (-4 ~ 158°F)
Linearity	± 1%(F.S.)
Hysteresis	± 1%(F.S.)
Weight	0.5kg (1.1lb)

NO.	PART NAME	MATERIAL	Q'TY	REMARK
5	ADJUST BOLT	STS 303	1	
4	BASE COVER	ALDC12	1	
3	DIAPHRAGM	N.B.R	2	
2	EXHAUST RING	ALDC12	1	
1	BASE BODY	ALDC12	1	

SURFACE TEXTURE	PRODUCT NAME VOLUME BOOSTER	YTC YOUNG TECH CO., LTD. <small>SEOUL, KOREA</small>	
FINISH TREATMENT	MODEL YT-300	TITLE VOLUME BOOSTER ASS'Y DWG	
MATERIAL	PROJECTION 3rd	SCALE 1 / 1	DRAWING NO. YT-300 (STANDARD)
OTHERWISE NOTE	GENERAL TOLERANCE	QUANTITY 1	SHEET No. 1 / 1
			REV. 2

