

Specification

Applicable Fluid	Air	
Applicable Inlet Pressure	Max. 1.5 MPa	
Adjustment Output Pressure Range	<input type="checkbox"/>	0.05 ~ 0.42 MPa (4.2 bar)
	<input type="checkbox"/>	0.05 ~ 0.84 MPa (8.4 bar)
Applicable Temperature	Standard	<input type="checkbox"/> -20 ~ 70 °C (-4~158°F)
	High	<input type="checkbox"/> -20 ~ 120 °C (-4~248°F)
	Low	<input type="checkbox"/> -40 ~ 70 °C (-40~158°F)
Min. Filtering Size	5 micron	
Air Connection	<input type="checkbox"/> PT 1/2	<input type="checkbox"/> NPT 1/2
Gauge Connection	<input type="checkbox"/> PT 1/4	<input type="checkbox"/> NPT 1/4
Material	Aluminum Diecasting	
Weight	1.13kg (2.49lb)	

Part List

NO.	PART NAME	MATERIAL	REMARK
1	ADJUST BOLT	STS 304 + PC	
2	CASE SPRING	ALDC12	
3	SPRING ADJUST	HSW3	
4	SEAT RELIEF	ACETAL	
5	DIAPHRAGM ASS'Y	NBR , STS 304, ACETAL	일반용
6	BODY BASE	ALDC12	내한, 내열용
7	STEM	C3604BD	
8	O-RING	NBR	일반용
		SILICONE	내한, 내열용
9	SEAT	C3604BD + NBR	일반용
		C3604BD + SILICONE	내한, 내열용
10	DEFLECTOR	ACETAL	
11	CASE FILTER	ALDC12	
12	FILTER ELEMENT	POLY ETHYLENE	일반, 내한용
		BRONZE	내열용
13	BAFFLE	ACETAL	
14	NIPPLE (1/4)	STS316	
15	AUTODRAIN ADAPTER	A6063	
16	CASE FILTER-AUTO DRAIN	ALDC12	
17	GUIDE FLOAT-AUTO DRAIN	ACETAL	
18	ASSY FLOAT-AUTO DRAIN	ACETAL	
19	LEVER FLOAT-AUTO DRAIN	STS303	
20	SEAT	PC + NBR	일반용
		PC + SILICONE	내한, 내열용
21	PLUG DRAIN-AUTO DRAIN	C3604BD + Ni 도금	

Characteristic

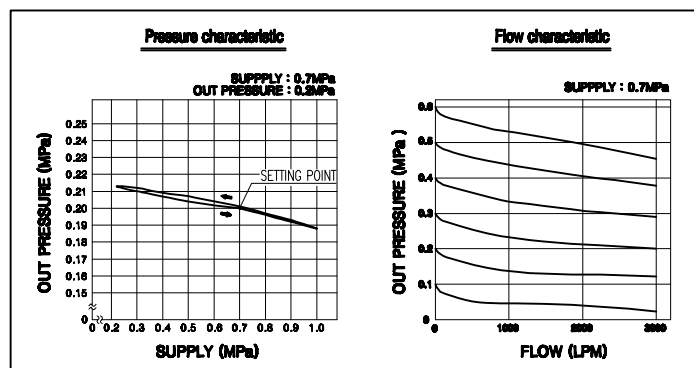

REV.NO.	REVISION DESCRIPTION	DRAWN / DATE	REVIEWED / DATE	APPROVED / DATE
△	ISSUE FOR APPROVAL	MDK/120531	JCS/120531	LYH/120531
△				

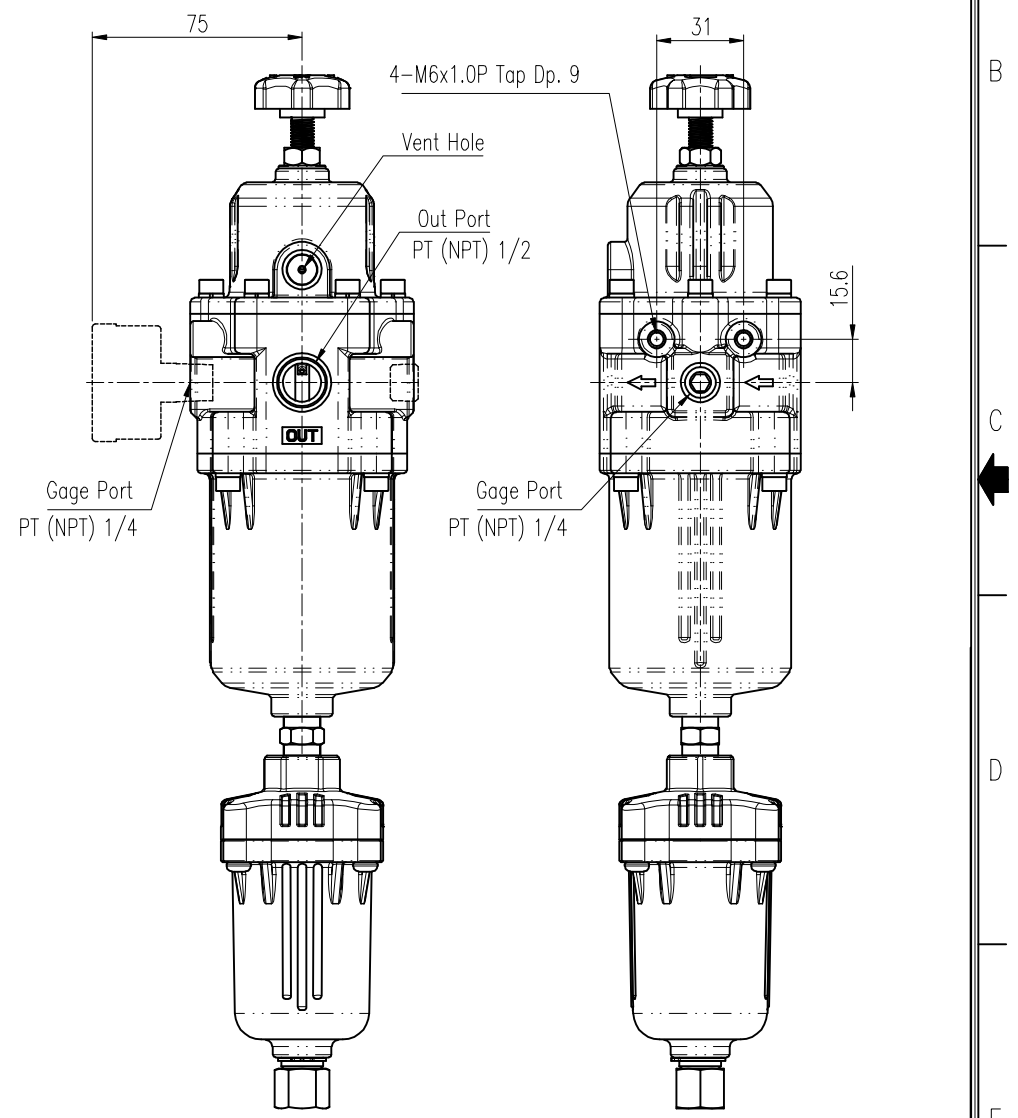
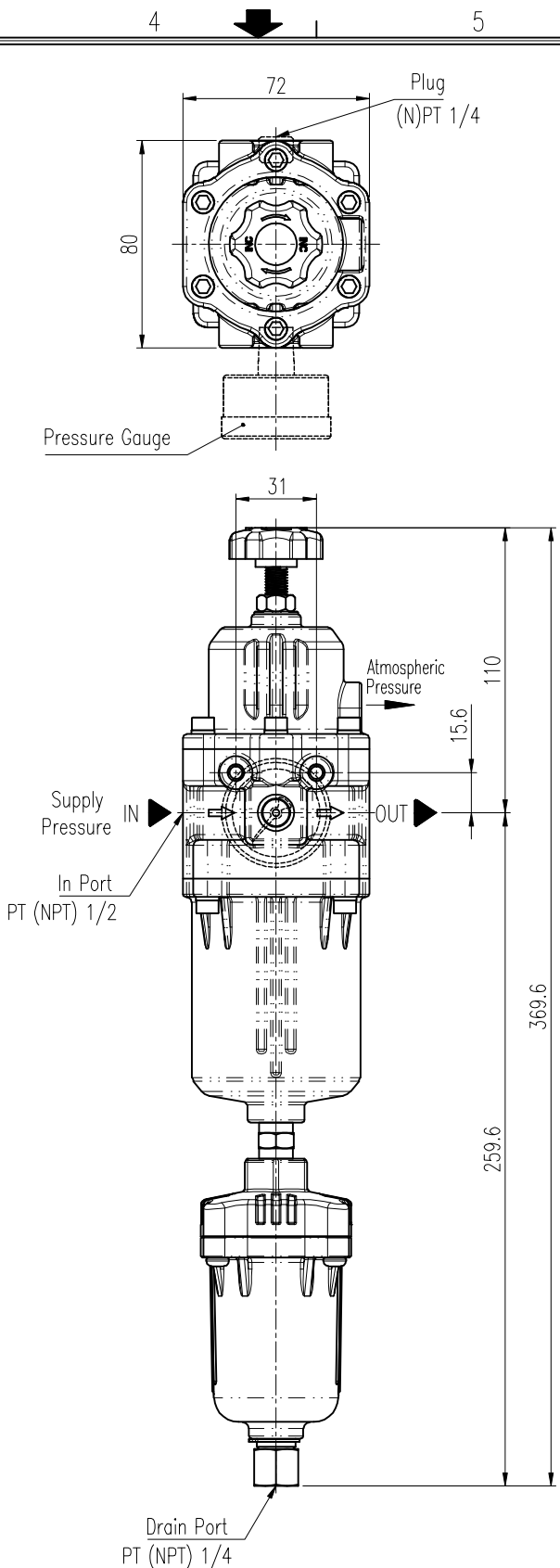
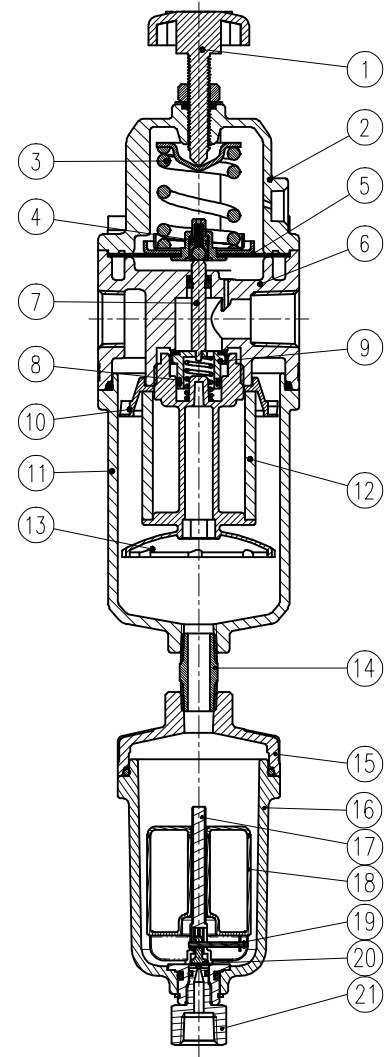

SURFACE TEXTURE	PRODUCT NAME AIR FILTER REGULATOR	YTC YOUNG TECH CO., LTD. <small>SEOUL, KOREA</small>	
FINISH TREATMENT	MODEL YT-220	TITLE AIR FILTER REGULATOR-AUTO DRAIN	
MATERIAL	PROJECTION	SCALE 1 / 2.5	DRAWING NO. YT-220 (AUTO DRAIN)
OTHERWISE NOTE	GENERAL TOLERANCE	QUANTITY	REV. 0
		SHEET No. 1 / 1	

PROJECT NAME _____