

△	DRAWING ARRANGEMENT	OSS/120315	JCS/120315	LYH/120315	REV.NO.	REVISION DESCRIPTION	DRAWN / DATE	REVIEWED / DATE	APPROVED / DATE
△	DRAWING ARRANGEMENT	KBJ/121112	JCS/121112	LYH/121112	△	DRAWING ARRANGEMENT	HSS/080305	JCS/080305	LYH/080305
△	DRAWING ARRANGEMENT				△	DRAWING ARRANGEMENT	LJS/110415	KCH/110415	LYH/110415
△	DRAWING ARRANGEMENT				△	DRAWING ARRANGEMENT	MDK/110812	JCS/110812	LYH/110812

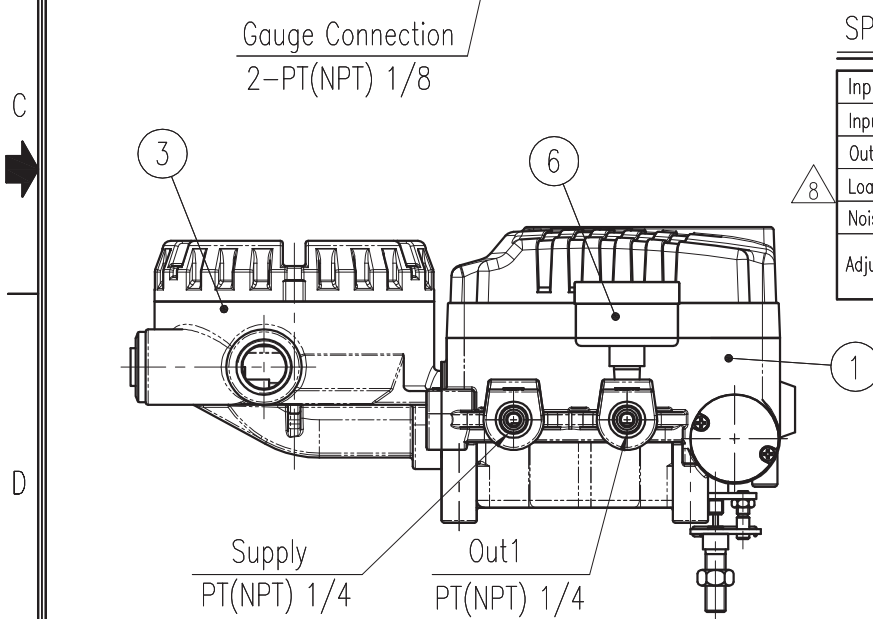
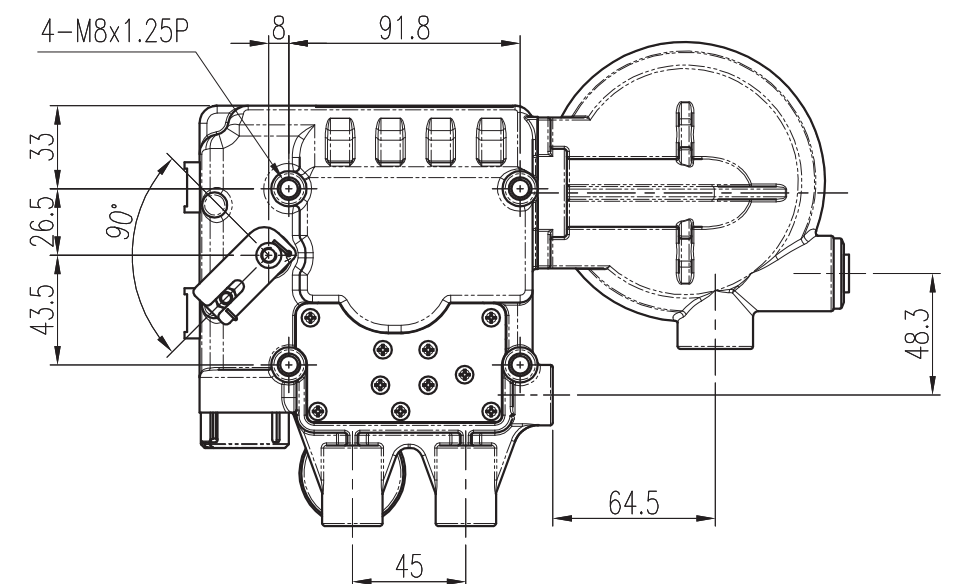
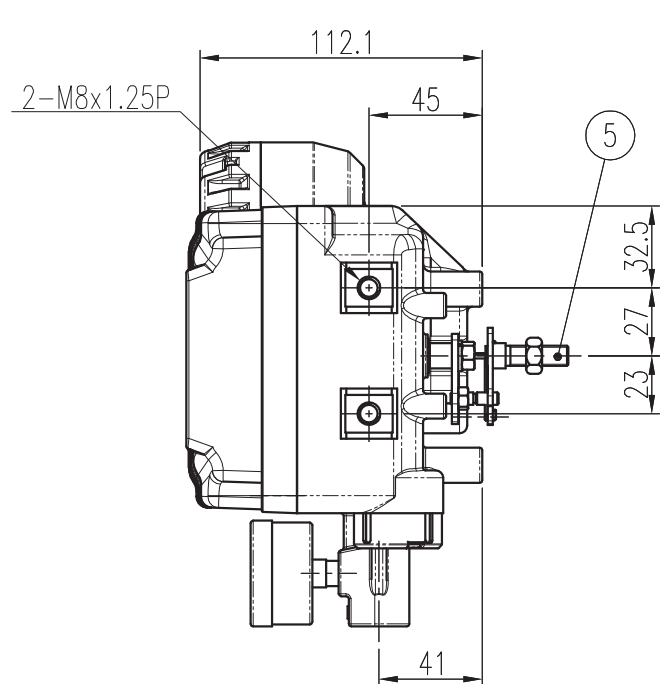
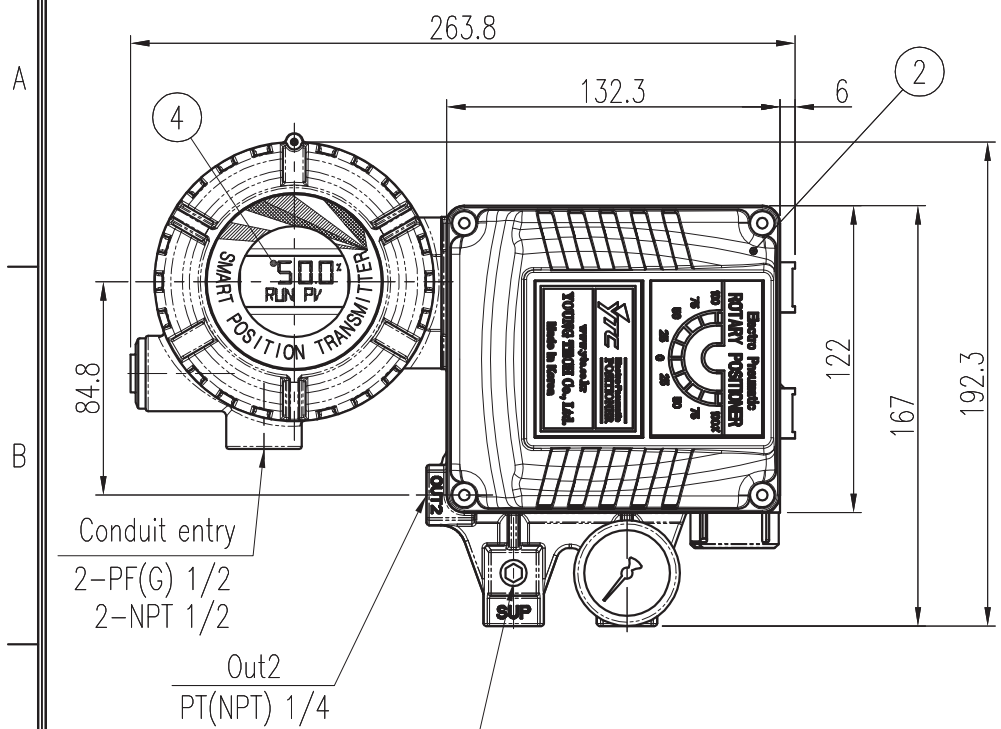

SPECIFICATIONS (LCD TYPE SMART TRANSMITTER)

Input Type	2 Wire	Protection	IP66
Input Signal	90°	Linearity	±0.5% F.S.
Output Signal	4 ~ 20mA DC	Hysteresis	±0.2% F.S.
Load Resistance	Max.880.Ω@ 28V DC	Sensitivity	±0.2% F.S.
Noise Range	50mVp.p	Supply Voltage	8 9 ~ 28V DC
Adjustment	Zero:±10% Span:60~110%	Explosion Proof	Non - Explosion

SPECIFICATIONS (POSITIONER)

Applicable Fluid	Air		Air Connection	PT(NPT) 1/4
Acting Type	<input type="checkbox"/> Single	<input type="checkbox"/> Double	Gauge Connection	PT(NPT) 1/8
Input Signal	4 ~ 20 mA DC		Conduit entry	PF 1/2 (G 1/2), NPT 1/2
Impedance	250±15 Ω		Explosion Proof	<input type="checkbox"/> Non-Explosion
Supply Pressure	0.14 ~ 0.7MPa (1.4 ~ 7bar)		Air Consumption	< 3 LPM (Sup.=0.14MPa, 1.4bar)
Stroke	10 ~ 150mm		Flow Capacity	> 80 LPM (Sup.=0.14MPa, 1.4bar)
Pressure Gauge	<input type="checkbox"/> 0.4MPa	<input type="checkbox"/> 0.8MPa	Protection	IP66
Linearity	±1.0% F.S.	±2.0% F.S.	Weight	2.7kg (6.1lb)
Hysteresis	±1.0% F.S.		Lever Type	<input type="checkbox"/> 10~40mm <input type="checkbox"/> 30~70mm <input type="checkbox"/> 60~100mm <input type="checkbox"/> 100~150mm
Sensitivity	±0.2% F.S.	±0.5% F.S.	Material	ALUMINUM DIECASTING
Repeatability	±0.5% F.S.			
Ambient Temp	Operation	-20°C ~ 70°C (-4 ~ 158°F)		
	Explosion	-20°C ~ 60°C (-4 ~ 140°F)		

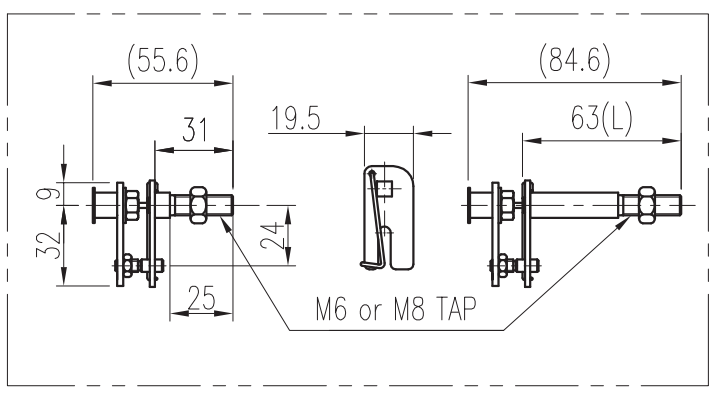

FORK LEVER TYPE

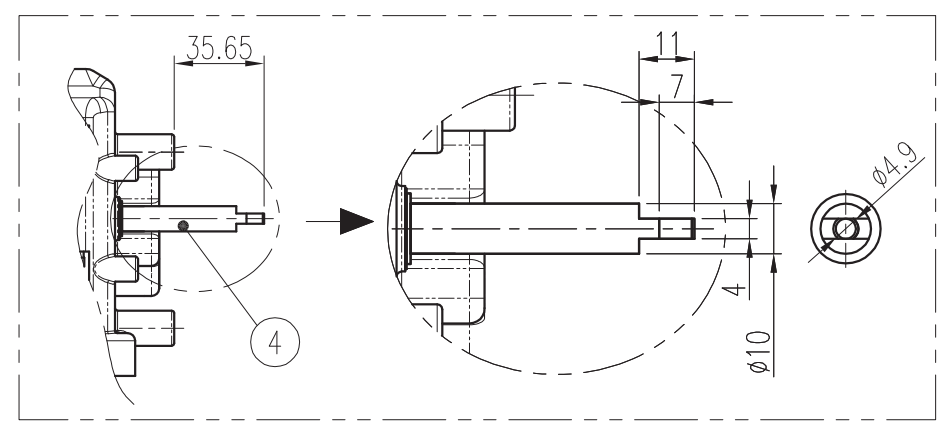

NAMUR SHAFT TYPE

6	PRESSURE GAUGE	STS304	1	
5	CONNECT LEVER ASS'Y	STS304	1	FORK LEVER, NAMUR
4	LCD	-	1	
3	JUNCTION BOX SPTM	ALDC12	1	
2	COVER BASE	ALDC12	1	
1	BODY BASE	ALDC12	1	
NO.	PART NAME	MATERIAL	Q'TY	REMARK
				PROJECT NAME

SURFACE TEXTURE	PRODUCT NAME	E/P POSITIONER with SPTM (INTERNAL, LCD)		YOUNG TECH CO., LTD. SEOUL, KOREA
FINISH TREATMENT	MODEL	YT-1000R		
MATERIAL	PROJECTION	3rd	SCALE	1 / 3
OTHERWISE NOTE	GENERAL TOLERANCE	QUANTITY	SHEET No.	1 / 1
		1		
DRAWING NO.				REV.
YT-1000R-SPTM (INTERNAL, LCD)				8